

Visio 2003

Introduction

<http://www.mousetraining.co.uk>

Table of Contents

Introduction	1
Getting Started	2
Visio Environment.....	3
SCREEN LAYOUT.....	3
Standard Toolbar	4
Formatting Toolbar.....	5
Task Pane	6
File Commands	7
SAVING A FILE.....	7
To Save a File for the First Time.....	7
To Save an Existing File.....	7
CLOSING A FILE.....	8
OPENING AN EXISTING FILE	8
Stencils	10
OPENING MORE STENCILS.....	10
MOVING BETWEEN STENCILS	11
CLOSING STENCILS	12
SEARCHING FOR A SHAPE ON A STENCIL	12
Working with Shapes.....	14
CREATING A SHAPE.....	14
SELECTING SHAPES.....	14
To Select a Single Shape	14
To Deselect A Shape	15
To Select Multiple Shapes Using the Keyboard.....	15
To Select Multiple Shapes Using the Multiple Select Tool.....	15
To Select Shapes Using the Area Select Tool	16
To Select Shapes Using the Lasso Select Tool.....	16
To Select All Shapes on a Page	17
MOVING SHAPES	17
DELETING SHAPES.....	17
RESIZING SHAPES	18
Resizing a Shape with the Mouse.....	18
Resizing a Shape with the Size & Position Window	18
ROTATING SHAPES	19
Changing the Centre of Rotation.....	19
FLIPPING SHAPES	20
DUPLICATING/COPYING SHAPES.....	20

Duplicating a Shape	20
Copying a Shape between Pages.....	21
Moving a Shape between Pages.....	21
CHANGING THE ATTRIBUTES OF A SHAPE	22
To Change Line (Border) Attributes	22
To Change Fill Attributes	23
STACKING SHAPES.....	24
Bringing Shapes to the Front/Back of a Stack	25
Bringing Shapes Forward/Backward One Level.....	25
ALIGNING SHAPES	25
DISTRIBUTING SHAPES	26
GROUPING SHAPES	27
To Group Selected Shapes	28
To Ungroup Shapes.....	28
Selecting a Shape within a Group	29

Pages & Views30

CREATING A NEW PAGE	30
Moving Between Pages.....	30
ZOOMING.....	30
Zooming via the Toolbar	30
Zooming via the Menu.....	31
Zooming via Keyboard Shortcuts	31
RULER & GRID.....	31
SNAP & GLUE.....	32
GUIDES	32

Working with Text.....33

TEXT BOXES	33
Adding Text to a Drawing	33
Editing Text in a Text Box.....	33
Moving a Text Box	34
Resizing A Text Box.....	34
Rotating a Text Box	34
SHAPES.....	35
Adding Text to a Shape.....	35
Editing Text in a Shape.....	35
Moving Text in a Shape.....	35
Resizing a Text Frame in a Shape.....	36
Rotating a Frame in a Shape	37
FORMATTING TEXT	37
To Select All Text in a Text Box or Shape	37
To Select Some of the Text in a Text Box or Shape	37
ALIGNMENT OF TEXT.....	38
Horizontal Alignment	38
Vertical Alignment.....	38
TABS WITHIN A TEXT BOX OR SHAPE	39
BULLETS WITHIN A TEXT BOX OR SHAPE	40

Connectors	41
OVERVIEW	41
CREATING A POINT-TO-POINT CONNECTION	41
CREATING A SHAPE-TO-SHAPE CONNECTION	42
Connecting Multiple Shapes.....	43
AUTOMATICALLY CONNECTED SHAPES	44
WORKING WITH CONNECTION POINTS	44
Adding a Connection Point.....	44
Deleting a Connection Point.....	44
Drawing Shapes	45
Background Pages.....	47
INSERTING A BACKGROUND PAGE	47
ASSIGNING A BACKGROUND PAGE	48
CREATING A BACKGROUND PAGE FROM AN EXISTING PAGE	49
EDITING AN EXISTING BACKGROUND PAGE.....	49
Custom Stencils	50
THE FAVOURITES STENCIL	50
Adding Shapes From an Existing Stencil to Favourites	50
Viewing Favourites	50
Adding Shapes From A Drawing to Favourites.....	52
Saving Changes to Favourites	52
NEW STENCILS.....	53
Creating a New Stencil.....	53
Adding Shapes to the New Stencil	53
Printing	54
PRINT PREVIEW	54
PRINTING YOUR DRAWING	54
Visio & Other Applications.....	56
Keyboard Shortcuts.....	57

Introduction

Visio is designed to help you create business and technical diagrams, including Organization Charts, Flow Charts and Office Layout Diagrams.

These diagrams are created with the use of sophisticated drawing tools and stencils of pre-drawn shapes that can be dropped onto the drawing page.

Getting Started

When you start Visio, it displays the **Choose Drawing Type** dialog box in which you can choose the predefined **Template** you wish to base your drawing on. These templates are arranged into **Category** folders shown on the left hand side.

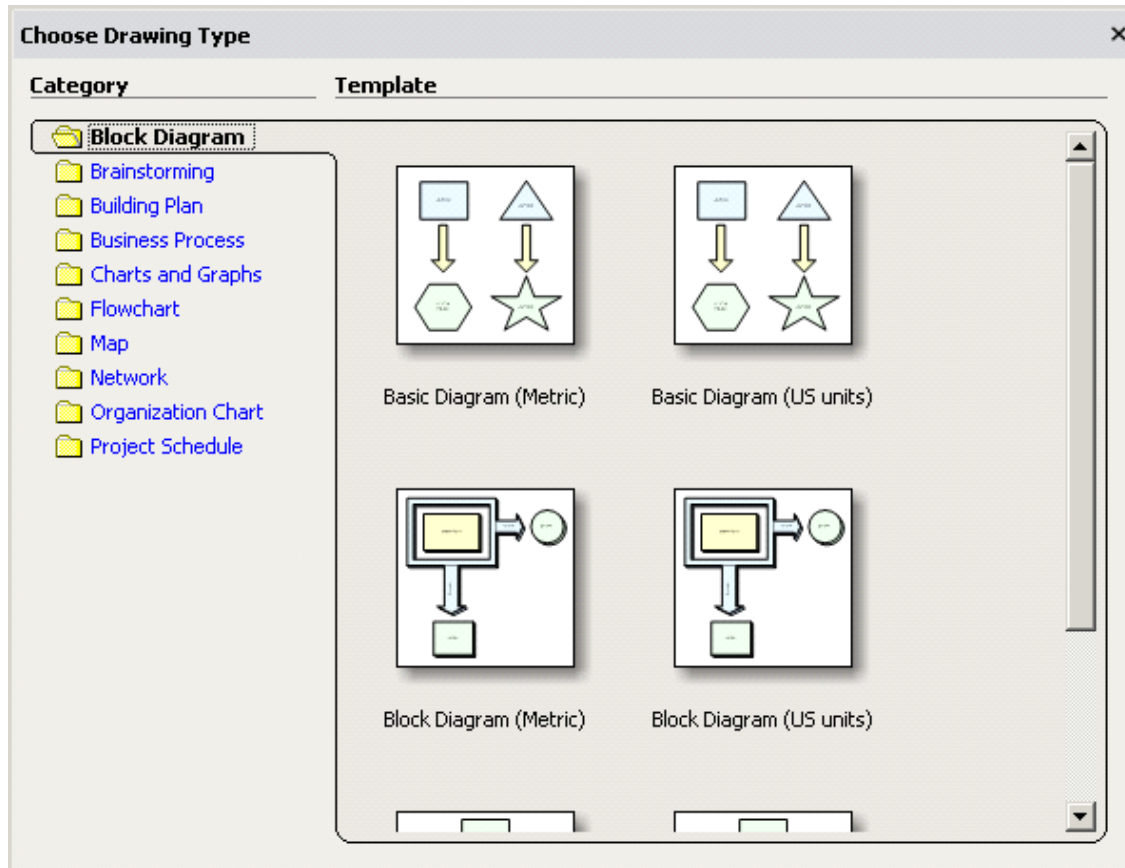

- To expand the folders, simply click on the folder icon.
- Move your mouse over the **Template** icon to see a description of that template (it will appear in the bottom left corner of the dialog box).
- Open the template you require by clicking on its icon.

Visio Environment

SCREEN LAYOUT

On the Visio screen you will notice a number of features that are similar to other Microsoft Office applications: Title Bar, Menu Bar, Standard and Formatting Toolbars and the Task Pane. You will also see the Stencils, which are particular to Visio.

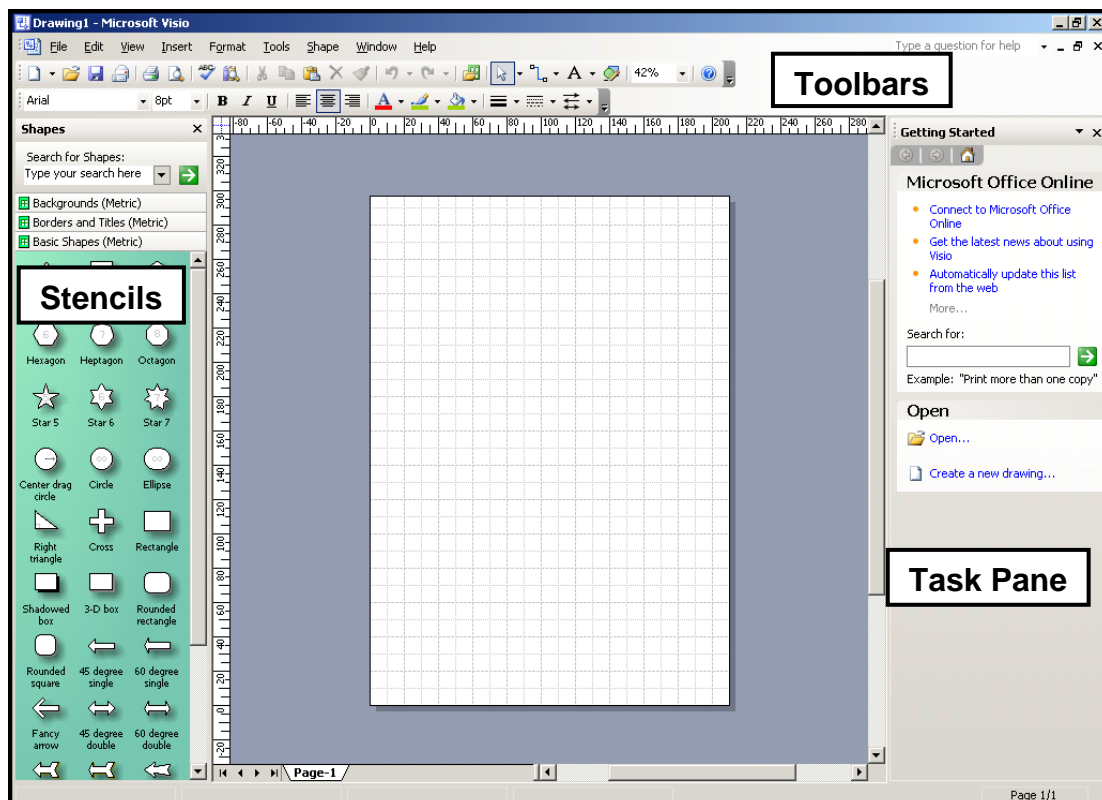























When Visio starts for the first time, the Standard and Formatting toolbars share one row on the screen, resulting in some of their icons being hidden from view. Similarly, the menus show most recently used commands first (only displaying the other commands after a short delay).

*These settings can be reversed by choosing **Customize** from the **Tools** menu, then on the **Customize** tab ticking the two option boxes at the top ('**Show Standard & Formatting toolbars on two rows**' and '**Always show full menus**').*

STANDARD TOOLBAR



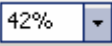





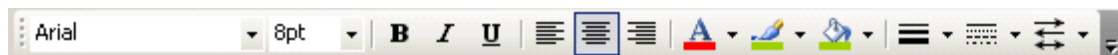





	New	To create a New drawing. The drop-down arrow can be used to select a Template.
	Open	To Open an existing drawing.
	Save	To Save the current drawing.
	E-mail	To E-mail the current drawing as an attachment.
	Print Page	To Print the current drawing.
	Print Preview	To Preview the current drawing.
	Spelling	To check the Spelling of all text in the current drawing.
	Research	To activate the Research task pane to enable you to search for information without the need to leave the Visio screen.
	Cut	To move data to the clipboard.
	Copy	To Copy data to the clipboard.
	Paste	To Paste data from the clipboard.
	Delete	To Delete the selected shape from the drawing page.
	Format Painter	To copy formatting from the current shape to others.
	Undo	To Undo the last action. The drop-down can be used to select as many as the last 20 actions.
	Redo	To Redo any actions that have been Undone. The drop-down can be used to Redo multiple actions.
	Shapes	To Open other stencils.

	Pointer Tool	To revert the mouse pointer to Select mode. The drop-down gives access to Lasso and Multiple Select modes.
	Connector Tool	To draw Connectors between shapes. The drop-down gives access to the Connection Point Tool.
	Text Tool	To create Text Boxes. The drop-down gives access to the Text Block Tool.
	Drawing Tools	To activate the Drawing toolbar.
	Zoom	To change the Zoom factor to be used on the current drawing.
	Help	To activate the Visio Help task pane.

FORMATTING TOOLBAR



	Font	To choose the Font type used for text.
	Font Size	To choose the Font size used for text.
	Bold	To apply Bold formatting to selected text, or all text within the selected shape.
	Italic	To apply Italic formatting to selected text, or all text within the selected shape.
	Underline	To apply Underline formatting to selected text, or all text within the selected shape.
	Align Left/Centre/Right	To Align text.
	Text Colour	To change the colour of selected text, or all text within the selected shape. The drop-down allows the choice of colour to be made.
	Line Colour	To change the Line (border) colour of the selected shape. The drop-down allows the

		choice of colour to be made
	Fill Colour	To change the Fill (inside) colour of the selected shape. The drop-down allows the choice of colour to be made
	Line Weight	To change the Line (border) weight of the selected shape. The drop-down allows the choice of weight to be made
	Line Pattern	To change the Line (border) pattern of the selected shape. The drop-down allows the choice of pattern to be made
	Line Ends	To add Line Ends (such as Arrow heads) to lines that have been drawn. This does not apply to shape borders.

TASK PANE

Each application in the Microsoft Office suite has a Task Pane available for specific tasks. The task pane is designed to make these tasks simpler to perform by making their options more accessible.

In Visio you will find it just as simple to perform these tasks without the use of the task pane. As such you may find it more useful to deactivate it in order to allocate more of the screen to your drawing page.

This can be done using the Close cross in the task panes top-right corner:

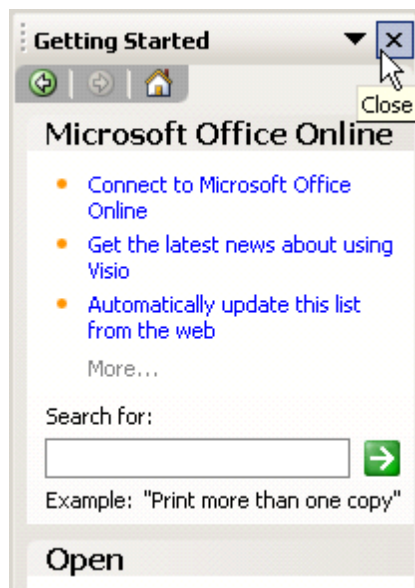

File Commands

SAVING A FILE

TO SAVE A FILE FOR THE FIRST TIME

- Select **Save** from the **File** menu or click Save  on the standard toolbar – the **Save As** dialog box will appear.

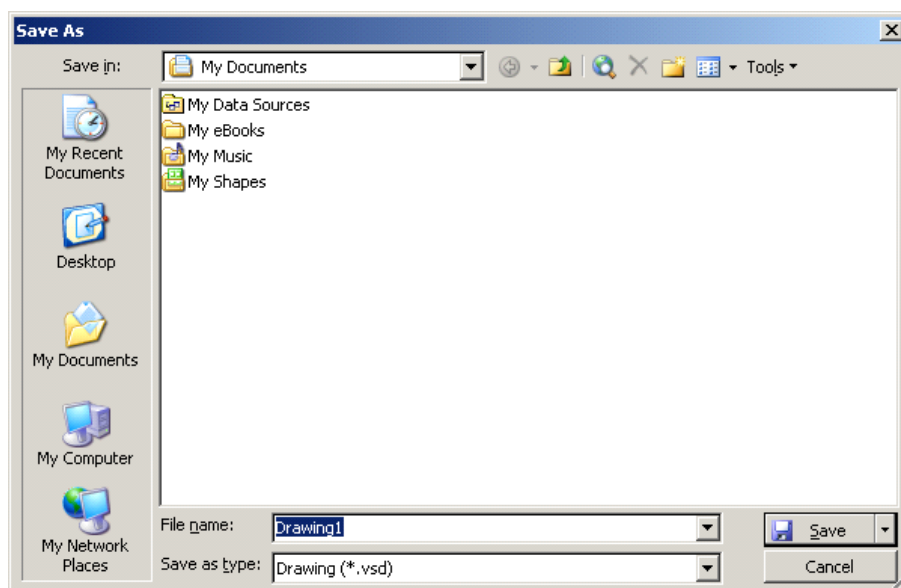

- Type a name for the file.
- Change the directory and/or the drive if required.
- Leave the file with the extension **.vsd**
- Choose **Save**.

TO SAVE AN EXISTING FILE

- Select **Save** from the **File** menu or click **Save** .

CLOSING A FILE

- Select **Close** from the **File** menu.

OR

- Click the Close Window icon in the top right of the screen

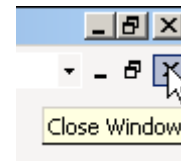

OPENING AN EXISTING FILE

- Select **Open** from the **File** menu.

OR

- Click **Open** .
- The open dialog box will appear:

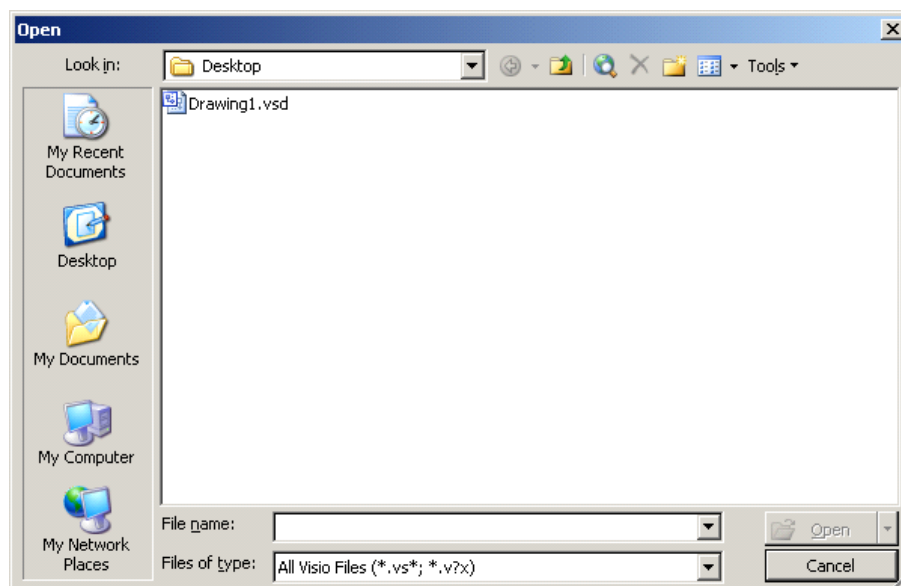

- Select the file you require.
 - Choose **Open**.
- OR**
- From the Open section of the Getting Started task pane on the right hand side:

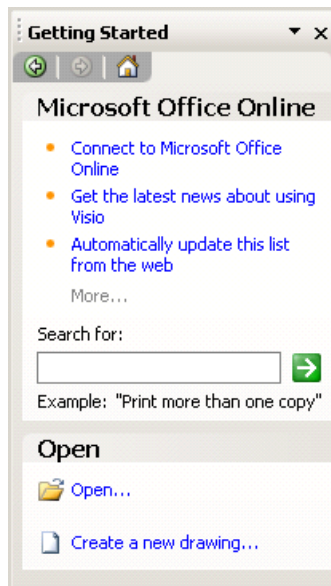

- Click on the **Open...** button.
- Choose the location of the existing file.

Stencils

A stencil is a collection of master shapes that are associated with a particular drawing type. Stencils are stored in stencil files (with a .vss extension). When you create a new drawing based on a template, the template opens stencils that are related to the drawing type. By default, stencils appear docked on the left side of the drawing window. You can also open a stencil independently of a template.

OPENING MORE STENCILS

Although templates will automatically open particular related stencils, other stencils can also be opened for use with a drawing.

- From the **File** menu, choose **Shapes**, and then choose a stencil from one of the Category folders listed:

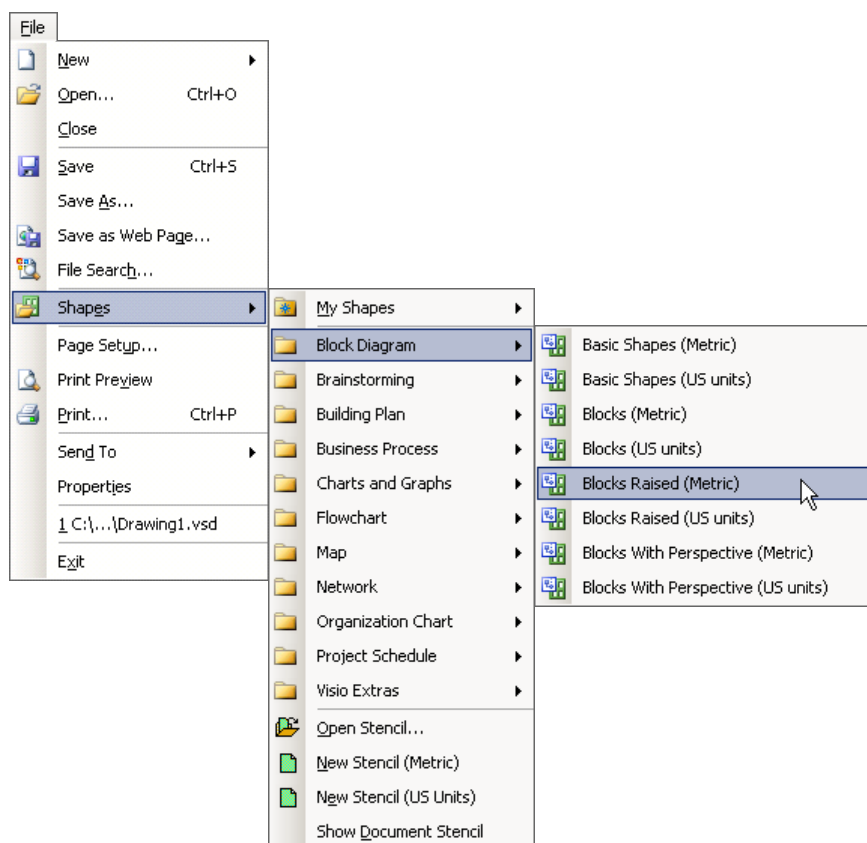

- The stencil opens docked, with the title bars of the other open stencils cascaded behind it:

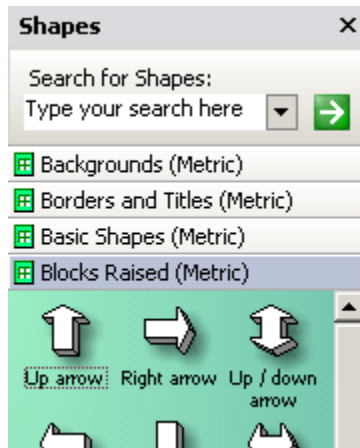

OR

- Click **Shapes**  on the standard toolbar, the stencil Category folders will appear.

MOVING BETWEEN STENCILS

- Click on the name of the stencil you wish to use, that stencil will appear at the front of the stencil column:

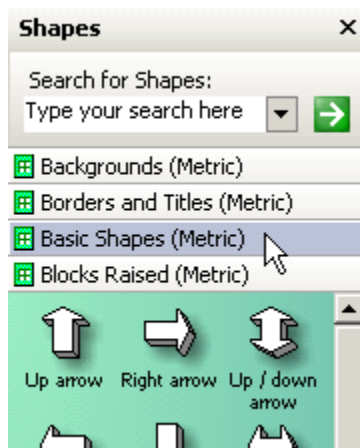

CLOSING STENCILS

- Click with your right mouse button on the name of the stencil you wish to close, a pop up menu will appear:

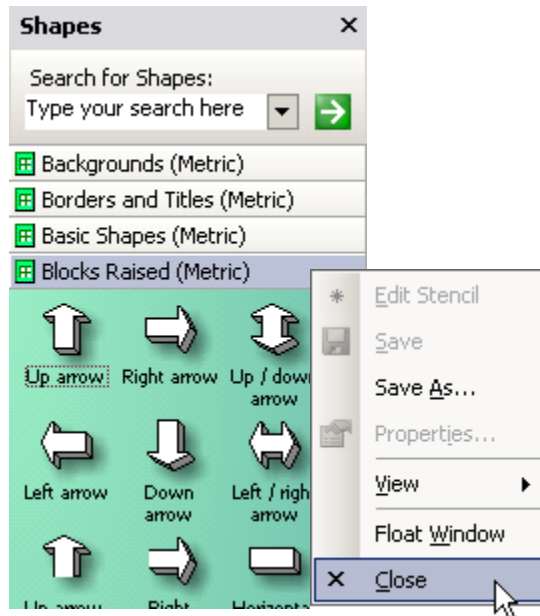

- Click on **Close** with your left mouse button.

SEARCHING FOR A SHAPE ON A STENCIL

If you are unsure which stencil contains the shape you require, then a search can be performed from the top part of the **Shapes** window.

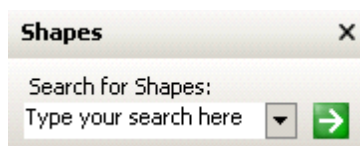

- Enter the word or phrase in the **Search for Shapes:** box and click the arrow to start the search.

- The results will appear in a temporary stencil:

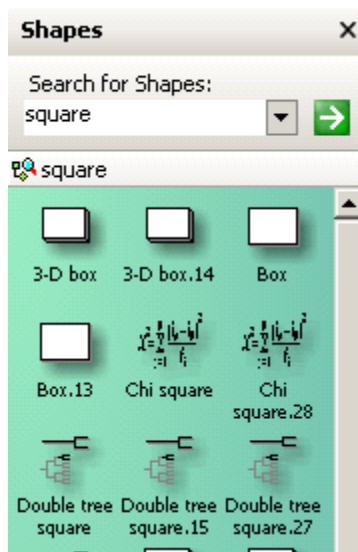

- When a new search is performed, these results will be replaced by those of the new search.
- The results stencil can be closed at any time in the normal way.

Working with Shapes

Shape is the general term for the objects you will find on a stencil and objects created using the drawing tools. These include geometric shapes such as rectangles, triangles and ellipses as well as more specialised shapes.

CREATING A SHAPE

- Locate the required shape on the stencil.
- Click and hold down the mouse button on the shape.
- Drag it over to your page.
- Let the mouse button go when you have positioned the shape in the preferred location.
- The shape will appear with 8 square (**Resize**) handles around the outside and 1 round (**Rotate**) handle at the top.
- These **Selection Handles** tell us the shape is active and able to be edited.

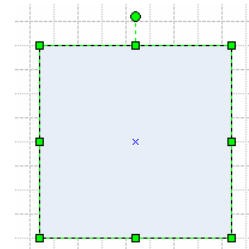

SELECTING SHAPES

Shapes must be selected before any action such as copying, deleting and formatting can go ahead.

TO SELECT A SINGLE SHAPE

- Click on the shape with the left mouse button.
- The selection handles described above will appear.

TO DESELECT A SHAPE

- Click on any blank area of the page.

TO SELECT MULTIPLE SHAPES USING THE KEYBOARD

- Select the first shape.
- Hold down the **SHIFT** key on the keyboard and select the second shape.
- The selection handles now form a rectangle that surrounds both of the shapes:

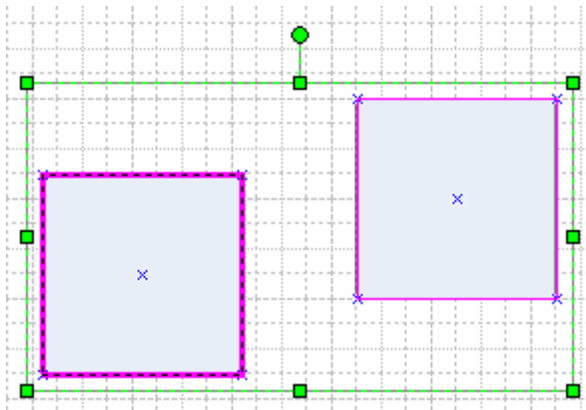

- Further shapes can also be selected using the same method.
- While still holding down the **SHIFT** a selected shape can be deselected by clicking it for a second time.

TO SELECT MULTIPLE SHAPES USING THE MULTIPLE SELECT TOOL

- Click the drop-down next to the Pointer Tool:
- Select the **Multiple Select** option.
- Click onto all the shapes to be selected, one after the other.
- Click a shape for a second time to deselect it.
- The **Multiple Select** option needs to be deactivated when it is no longer needed.

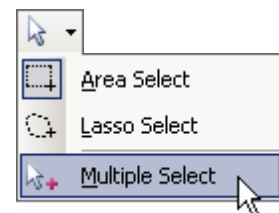

TO SELECT SHAPES USING THE AREA SELECT TOOL

This method involves dragging a selection box around the shape or shapes to be selected.

- Starting above and to the left of your shapes, click and drag your mouse towards the bottom right of your shapes:

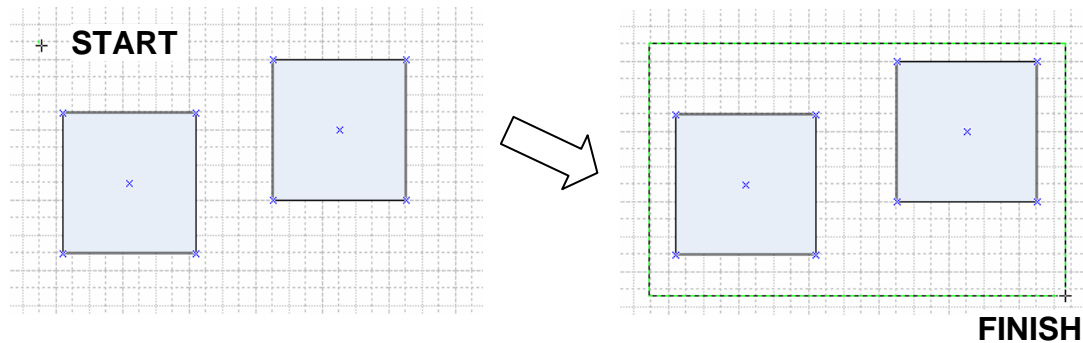

- Make sure all parts of the required shapes are within the selection box.
- Release the mouse button when you are happy with your box; if not, click away so nothing is selected and try to drag the box again.

TO SELECT SHAPES USING THE LASSO SELECT TOOL

This method involves drawing a selection 'lasso' of any shape around the shape or shapes to be selected.

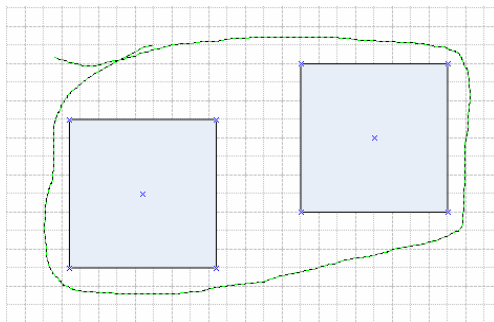

- Click the Pointer Tool drop-down and select **Lasso Select**.
- Click and drag with the mouse to start drawing the lasso.
- Ensure the shapes to be selected are fully within the lasso.
- If possible overlap the start and end points of the lasso (although this is not always essential).

Both the Area Select and the Lasso Select methods can be used in conjunction with the Multiple Select method in order to easily select multiple shapes which are positioned in different parts of the drawing page.

TO SELECT ALL SHAPES ON A PAGE

- In the **Edit** menu, choose **Select All**.

OR

- Press **CTRL+A**.

MOVING SHAPES

- Point your mouse at the shape to be moved.

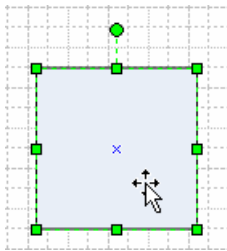

- Click and hold down the mouse button.
- Drag the shape to the new location.
- Release the mouse button.

DELETING SHAPES

- Select the shape to be deleted.
- Press the **Delete** key.

OR

- Use Delete  on the formatting toolbar.

RESIZING SHAPES

RESIZING A SHAPE WITH THE MOUSE

- Select the shape to be resized.
- Move the mouse pointer to the required **Resize** handle:

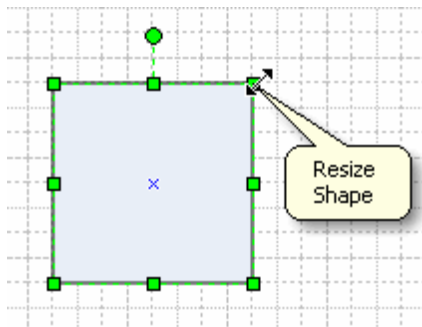

- Drag the handle until the shape is at the required size.
- Release the mouse button.

Click and drag on any corner when resizing to maintain the shape's height-to-width proportions.

RESIZING A SHAPE WITH THE SIZE & POSITION WINDOW

- Select the shape to be resized.
- From the **View** menu, select **Size & Position** – the following window will appear in the bottom left of the screen:

Size & Position	X	85 mm
	Y	215 mm
	Width	40 mm
	Height	40 mm
	↺ Angle	0 deg
	X Pin Pos	Center-Cent

- Increase/decrease the **Width** and **Height** values to change the size of the shape.
- The **X** and **Y** values refer to the position of the shape on the drawing page.

ROTATING SHAPES

- Select the shape to be rotated.
- Select **Rotate Left** or **Rotate Right** from **Rotate or Flip** in the **Shape** menu:

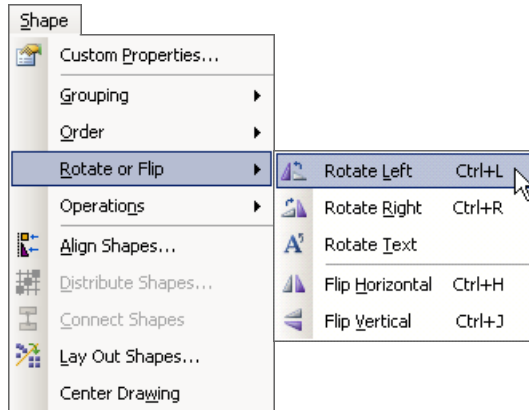

OR

- Select the shape.
- Use the **Rotate** handle to drag the shape round as far as necessary:

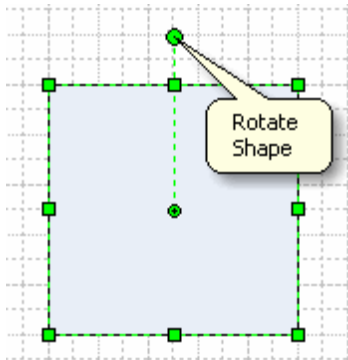

CHANGING THE CENTRE OF ROTATION

The centre of rotation is normally positioned in the centre of the shape and defines the point at which the shape will rotate. The centre of rotation can be moved at any time.

- Select the shape and move the mouse pointer over the Rotate handle (see above).

- The **Centre of Rotation** will appear in the centre of the shape:

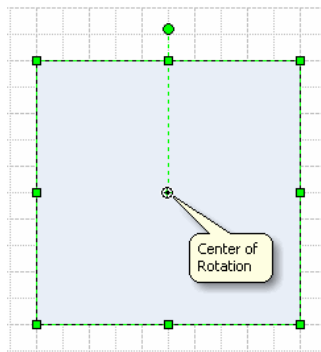

- Move the mouse over the centre of rotation and click & drag it to another position.

FLIPPING SHAPES

- Select the shape to be flipped.
- Select **Flip Horizontal** or **Flip Vertical** from **Rotate or Flip** in the **Shape** menu:

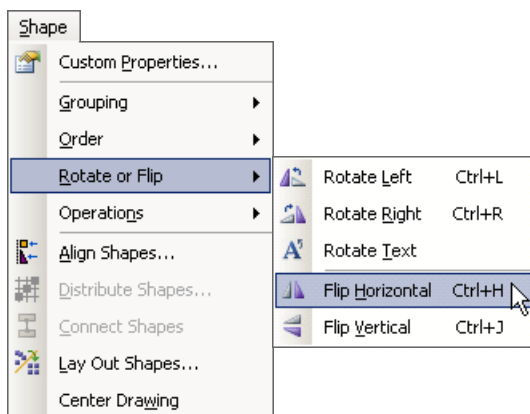

DUPLICATING/COPYING SHAPES

DUPLICATING A SHAPE

- Select the shape to be duplicated.

- Select **Duplicate** from the **Edit** menu, and a copy of the shape will appear directly beside the original:

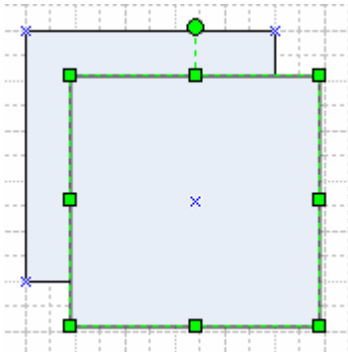

- **CTRL+D** will do the same.

OR

- Hold down the **CTRL** key and move the shape to its new position, a copy is created.

COPYING A SHAPE BETWEEN PAGES

- Select the shape to be copied.
- Select **Copy** from the **Edit** menu.
- Move to the page where the copy is required.
- Select **Paste** from the **Edit** menu.

MOVING A SHAPE BETWEEN PAGES

- Select the shape to be moved.
- Select **Cut** from the **Edit** menu.
- Go to the page where the shape is required.
- Select **Paste** from the **Edit** menu.

OR

- Use Cut , Copy  and Paste  from the standard toolbar.

CHANGING THE ATTRIBUTES OF A SHAPE

Attributes, such as line and fill colour, can be changed to alter the appearance of a shape.

TO CHANGE LINE (BORDER) ATTRIBUTES

- Select the shape for which the line attributes are to be changed.
- Select **Line** from the **Format** menu – the **Line** dialog box will appear:

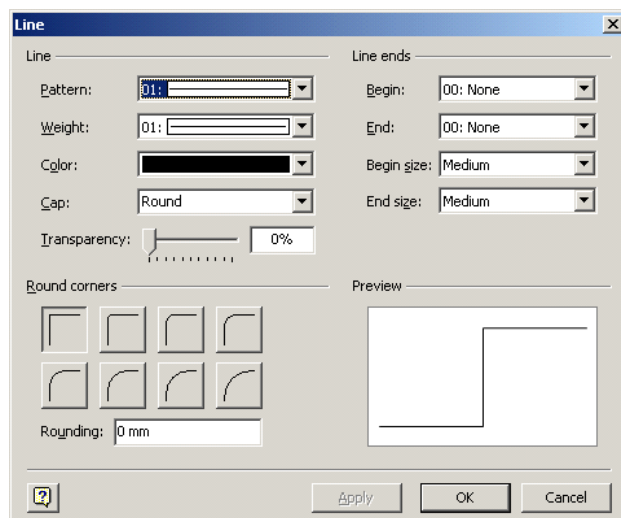

Line

- Pattern** Changes the style of the line, e.g. dotted, dashed etc.
- Weight** Changes the thickness of a line or a line around a shape.
- Colour** Changes the colour of the line or the line colour of a shape.
- Cap** Makes the ends of a line either round or square. This may not be visible if the line is fairly thin.
- Transparency** This sets the transparency of the line, from 0 to 100.

Line Ends

- Begin/End** Changes the style of the beginning/end of the line, e.g. adds arrowhead.

Begin/End Size Changes the size of the beginning/end of line attachments.

Round Corners Gives you the option to smooth the corners of the line or shape.

- Choose **OK** to finish.

OR

- Select the shape or line.
- From the formatting toolbar:



Line Colour.



Line Weight



Line Pattern



Line Ends.

TO CHANGE FILL ATTRIBUTES

- Select the shape for which the fill attributes are to be changed.
- Select **Fill** from the **Format** menu – the **Fill** dialog box will appear:

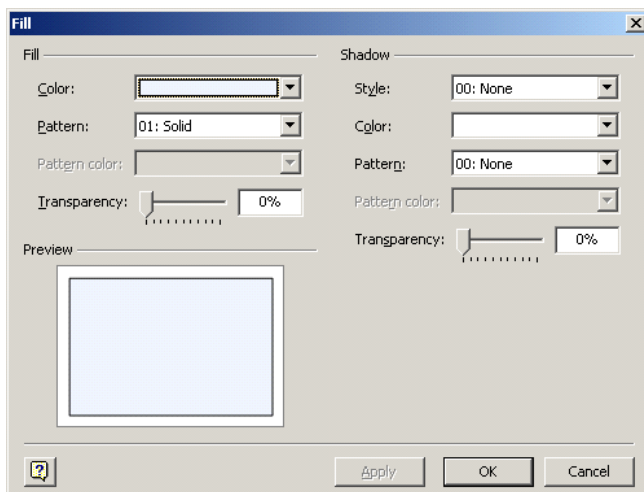

Fill

Colour Allows the colour of the shape to be chosen.

Pattern Allows a pattern to be applied to the fill of the shape.

Pattern Colour Allows the colour of the pattern to be chosen.

Transparency Sets the Transparency of the fill, from 0 to 100.

Shadow Some Shadow settings can be set from this section, but the **Shadow** dialog box (from the **Format** menu) gives more options.

- Choose **OK** to finish.

OR

- Select the shape.
- From the formatting toolbar:



Fill Colour.

STACKING SHAPES

When you are working with shapes, you will find that you sometimes need to stack them to get the effect you want. When you stack shapes on top of each other, they will overlap. Visio has commands to move shapes up or down in a stack.

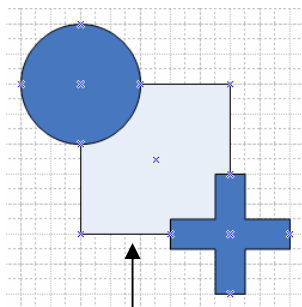

Select the
shape you
want on top

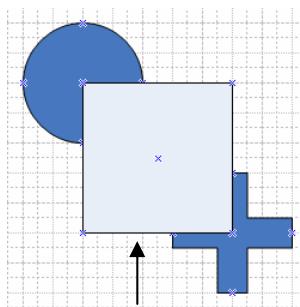

Choose
**Bring to
Front**

BRINGING SHAPES TO THE FRONT/BACK OF A STACK

The **Bring to Front** and **Send to Back** commands move a shape to the top or bottom of the stack.

- Select the shape you want to move.
- From the **Shape** menu, choose **Order**. The following sub-menu will appear:

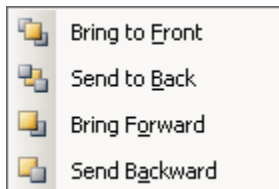

- Select **Bring to Front** or **Send to Back**.

BRINGING SHAPES FORWARD/BACKWARD ONE LEVEL

The **Bring Forward** and **Send Backward** commands move a shape up or down in the stack one level at a time.

- Select the shape you want to move.
- Select **Bring Forward** or **Send Backward** from the **Order** option of the **Shape** menu.

ALIGNING SHAPES

If you have created a number of shapes, you can align the entire group on their left/right borders, their top/bottom border or their centres. You do not have to select and move each shape individually.

- Select the first shape, the handles will be green. This will be the **master** shape.
- Select the other shapes using the **SHIFT** key (or the **Multiple Select** option from the Pointer Tool drop-down).
- The green handles will surround all of the selected shapes. The first shape (the master) will now have a thick pink border, while the subsequent shapes selected will have a thinner pink border:

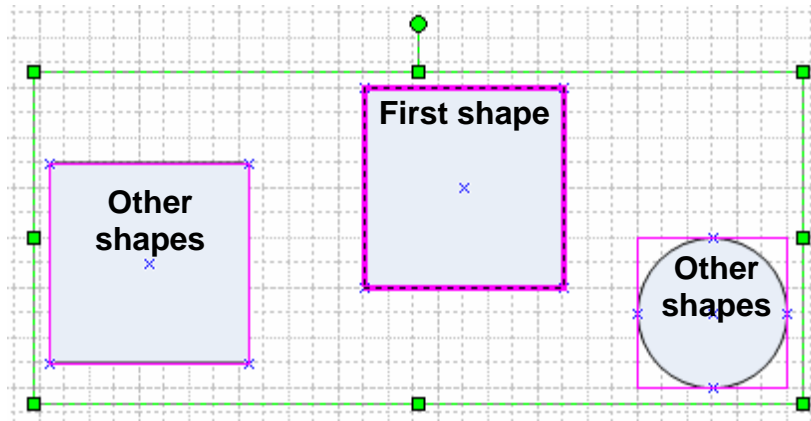

- Choose **Align Shapes** from the **Shape** menu, the **Align Shapes** dialog opens:

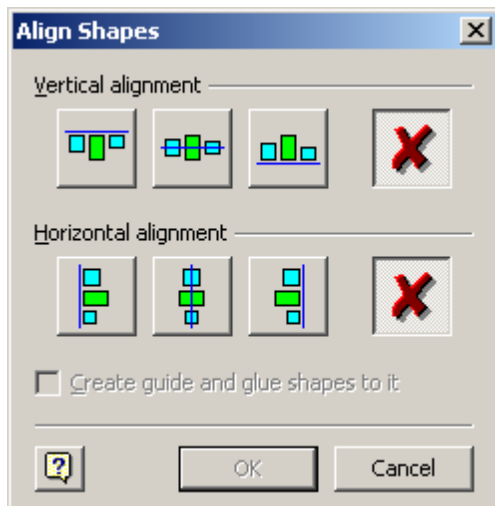

- Select the type of alignment you require. The green shape on each of the icons refers to the master shape.
- Click on **OK**.

DISTRIBUTING SHAPES

If you have created a number of shapes, you can distribute space equally between them.

- Select the shapes you want to distribute space between.

- Choose **Distribute Shapes** from the **Shape** menu, the **Distribute Shapes** dialog opens:

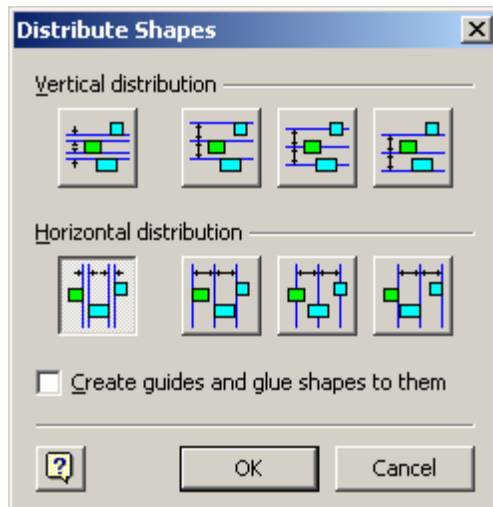

- Select the type of distribution you want.
- Click on **OK**.

GROUPING SHAPES

When you have selected two or more shapes, you can create a group. Once you have a group, any attribute you choose such as shadow or line colour, is assigned to all the individual shapes within a group – as long as it applies (e.g. you cannot have a line with a shaded fill). The grouped shapes all move and rotate as a group.

Two Shapes Selected – NOT Grouped

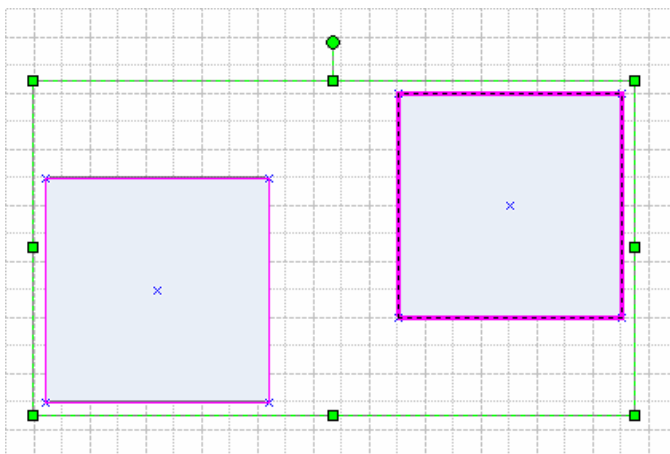

Two Shapes Grouped

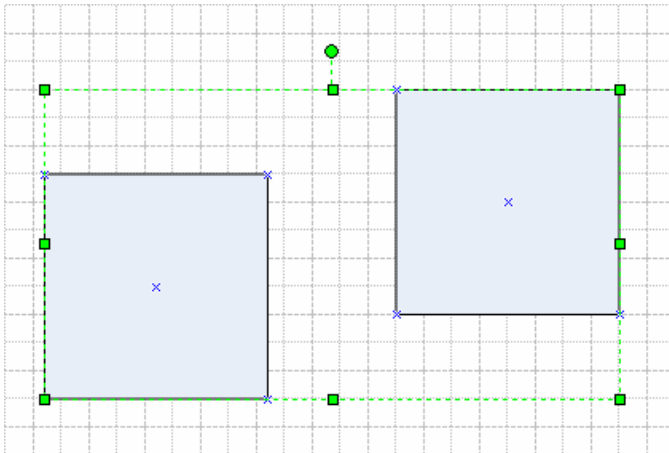

TO GROUP SELECTED SHAPES

- Select the shapes to be grouped.
- Choose **Grouping** and then **Group** from the **Shape** menu.

OR

- Press **CTRL+G**.

TO UNGROUP SHAPES

- Select the group by clicking on one of its shapes.
- Choose **Grouping** and then **Ungroup** from the **Shape** menu.

OR

- Press **CTRL+SHIFT+U**.

SELECTING A SHAPE WITHIN A GROUP

- Select the group.
- Select the shape you want to alter. When the shape has been selected, its selection handles will contain small crosses.

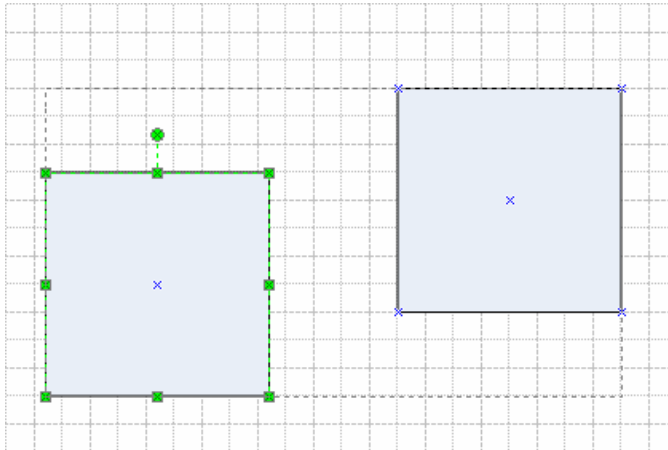

- Format the shape.
- Or click & drag the shape to move it within the boundaries of the group.
- Click away from the shape to deselect the group when you have finished.

Pages & Views

CREATING A NEW PAGE

- A new page can be added after the page that is currently displayed.
- Select **New Page** from the **Insert** menu.
- Choose **OK**.

MOVING BETWEEN PAGES

- Page Tabs appear at the bottom of the screen:



- Click onto a Tab to switch to that page.

OR

- Pressing **CTRL+ Page Up/Down** will move you forward or backward one page at a time through the file.

ZOOMING

You can zoom in and out of your drawing to see either the whole page or just a portion of it.

ZOOMING VIA THE TOOLBAR

- The Zoom drop-down  on the standard toolbar can be used.

ZOOMING VIA THE MENU

- Choose **Zoom** from the **View** menu. The following sub-menu will appear:

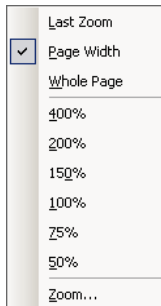

- Select the desired magnification.
- The **Page Width** and **Whole Page** options are especially useful.

ZOOMING VIA KEYBOARD SHORTCUTS

Position the mouse pointer over the top of the shape on which you want to zoom.

CTRL+SHIFT

+ Left mouse button click	Zoom in
+ Right mouse button click	Zoom out
+ Left mouse button & drag	Marquee zoom in
+ Right mouse button & drag	Hand, scroll page

CTRL+W This is the same as choosing **Whole Page** from the Zoom menu.

RULER & GRID

The page has a visible Grid of squares designed to help with the positioning of shapes. The size of the squares on this grid will change as you zoom in and out of the page.

There are also vertical and horizontal Rulers found on the left and top of the drawing page.

Both of these features can be adjusted from the **Ruler & Grid** option of the **Tools** menu.

SNAP & GLUE

As one shape is moved close to another on a drawing page, the two will tend to line up exactly without a gap between them. This is a feature called Snap. This is typically what you would want to happen to help with the overall appearance of your drawing. The feature can be deactivated by choosing **Snap & Glue** from the **Tools** menu.

GUIDES



Guides are another method designed to help with the positioning of shapes. Both horizontal and vertical guides can be introduced to the drawing page.

- Move the mouse pointer to one of the rulers (the top ruler for a horizontal guide, the left ruler for a vertical).
- Click & drag onto the drawing page. The guide will be created wherever the mouse is released.
- Guides can be moved, copied and deleted just like normal shapes.

Working with Text

TEXT BOXES

ADDING TEXT TO A DRAWING

- Select Text Tool  from the standard toolbar.
- Click and drag a box on the page where you want the text to go.
- Type the text.
- Click on the Pointer Tool  when finished:

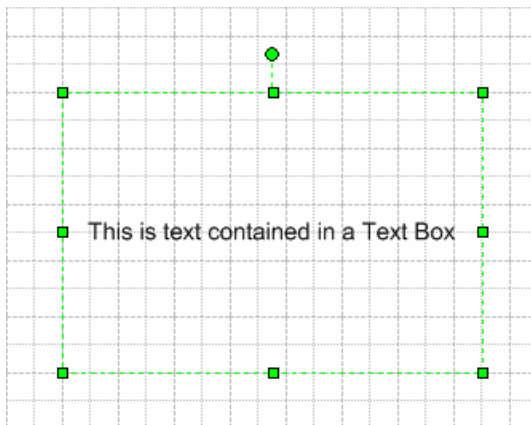

- This has created a **Text Box** to hold the text.

EDITING TEXT IN A TEXT BOX

- Double click on the text box to be edited, all text will be highlighted.
- Click into the text and start editing.
- Click outside the text box when finished.

MOVING A TEXT BOX

- Click on the text to be moved – the handles will appear around the outside.
- Point at the text or the border (but not the space in between):

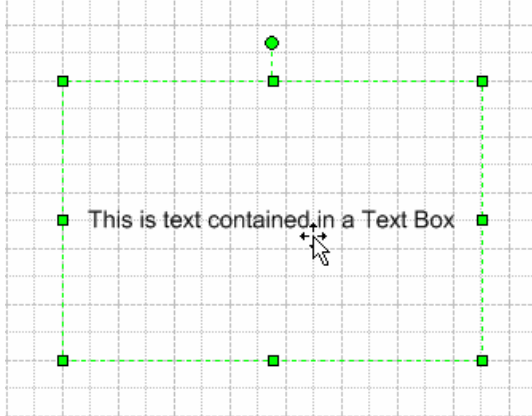

- Click and drag to the new position.

RESIZING A TEXT BOX

- Click on the text box to be resized.
- Drag the handles to resize the box (the font size will not change):

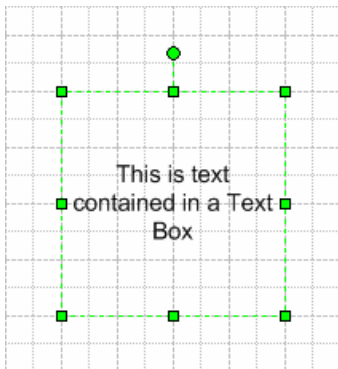

ROTATING A TEXT BOX

This is the same process as rotating a shape (see Rotating Shapes on Page 19).

SHAPES

ADDING TEXT TO A SHAPE

- Drag the shape onto the page or click to select an existing shape.
- Start typing.
- Click outside of the shape when finished:

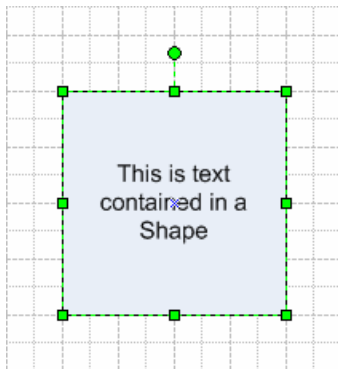

EDITING TEXT IN A SHAPE

- Double click on the shape whose text is to be edited, all text will be highlighted.
- Click into the text and start editing.
- Click outside the shape when finished.

MOVING TEXT IN A SHAPE

The text in a shape is housed in a Text Frame (or Text Block). This text frame starts off with the same dimensions as the shape, and is positioned on top of it. It can therefore be difficult to see.

The text frame has the ability to be moved or resized independently of the shape, if required. This is done by activating the **Text Block Tool**, from the Text Tool drop-down on the standard toolbar:

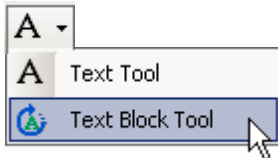

- With the Text Block Tool activated, move the mouse cursor over the text to be moved:

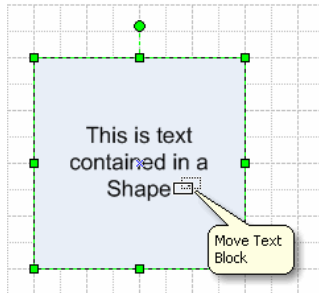

- Click and drag the text frame to its new position:

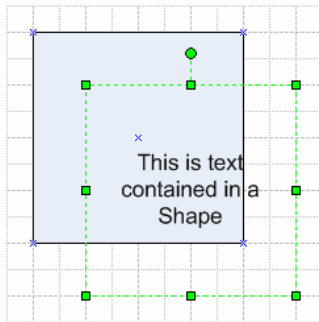

RESIZING A TEXT FRAME IN A SHAPE

- Activate the Text Block Tool.
- The selection handles that are visible will now resize the Text Frame, not the shape.

ROTATING A FRAME IN A SHAPE

- Activate the Text Block Tool.
- The Rotate handle that is visible will now rotate the Text Frame, not the shape.

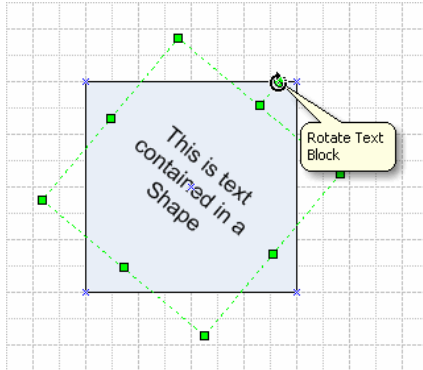

FORMATTING TEXT

Text attributes such as font, size and colour can be changed using the formatting toolbar and commands from the **Format** menu. Before text can be formatted it has to be selected.

TO SELECT ALL TEXT IN A TEXT BOX OR SHAPE

- Click on the text to be selected – handles will appear around the box.
- The box (and therefore all of its text) is now selected.

TO SELECT SOME OF THE TEXT IN A TEXT BOX OR SHAPE

- Select the text box.
- Click at the start of the text to be selected.
- Click and drag the mouse to highlight and select the required text.

ALIGNMENT OF TEXT

HORIZONTAL ALIGNMENT

- Select the shape.
- Choose **Text** from the **Format** menu, then choose the **Paragraph** tab.
- Choose the desired alignment from the **Horizontal Alignment** drop down box:

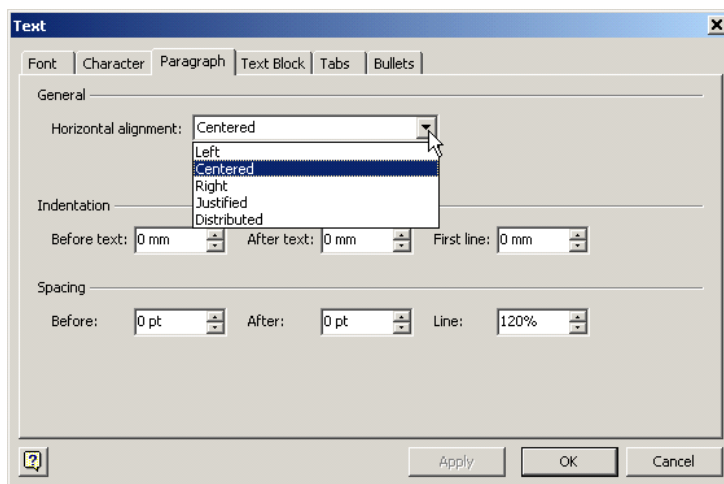

- Choose **OK**.

OR

- Use the Align icons  on the formatting toolbar.

VERTICAL ALIGNMENT

- Select the shape.
- Choose **Text** from the **Format** menu, then choose the **Text Block** tab.

- Choose the desired alignment from the **Vertical Alignment** drop down box:

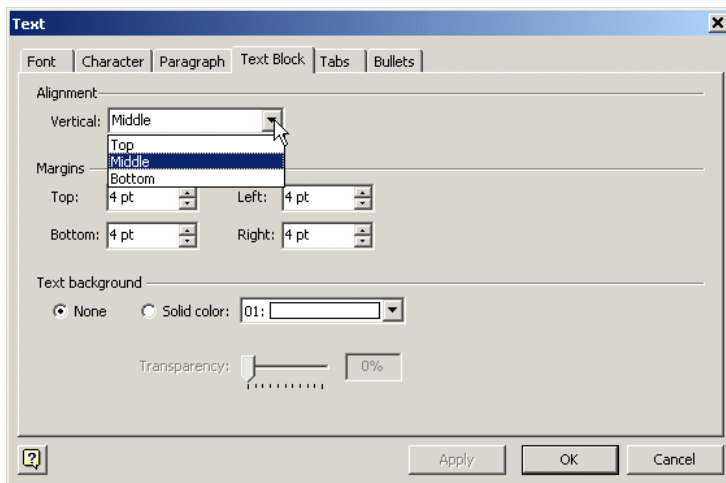

- Choose **OK**.

TABS WITHIN A TEXT BOX OR SHAPE

- Select the text box.
- Choose **Text** from the **Format** menu, then choose the **Tabs** tab.
- In the **Tab stop position** box on the right of the dialog box, enter the position at which you want the tab:

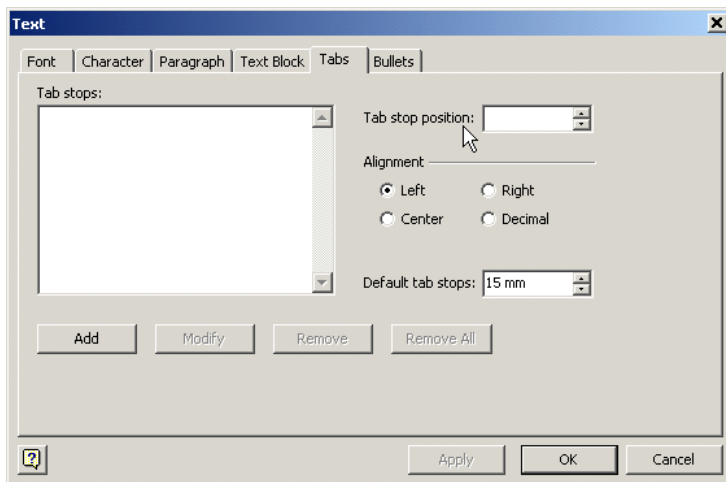

- Choose what type of alignment you require from the **Alignment** section.
- Choose **Add**.

- Repeat the above steps for any other tabs.
- Choose **OK**.
- By pressing the **Tab** key, you will move to the programmed positions.

BULLETS WITHIN A TEXT BOX OR SHAPE

- Select the text box.
- Choose **Text** from the **Format** menu, then choose the **Bullets** tab.
- Choose the bullet **Style** required:

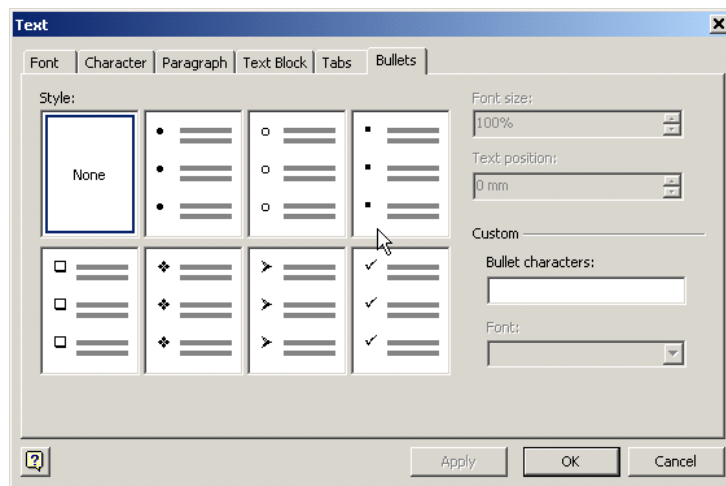

- Choose **OK**.

Connectors

OVERVIEW

Connectors are lines that connect your shapes. Once a connection has been made, when the shape is moved, the connector points stay connected and move with the shape.

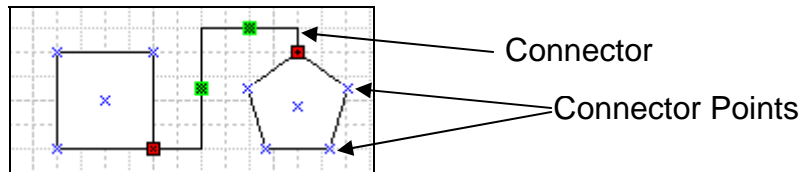

You can connect any two shapes together. You can bring your shapes out already connected or connect them when they are on the drawing page.

CREATING A POINT-TO-POINT CONNECTION

- Choose the Connector Tool .
- Move the mouse over one of the connection points of the first shape:

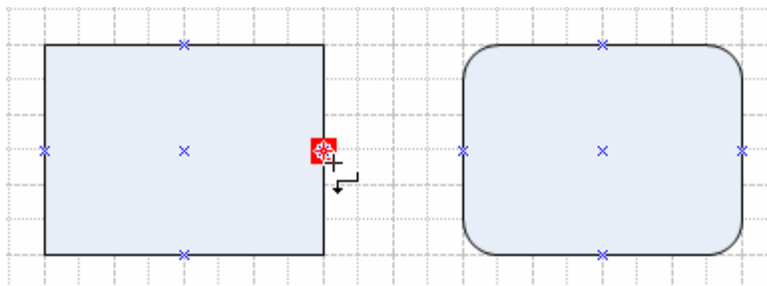

- Click & Drag to a connection point on the second shape:

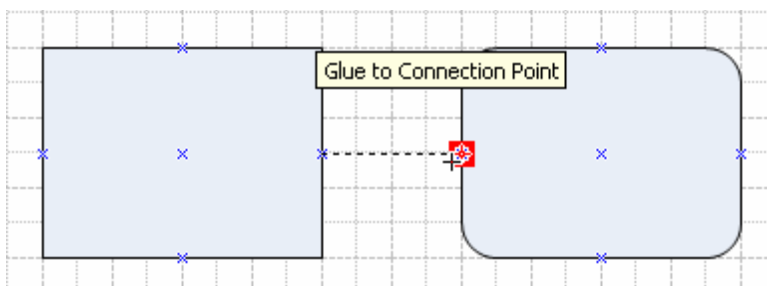

- The connector is now fixed to the two connection points. This is indicated by the 'x' and '+' symbols in the red squares:

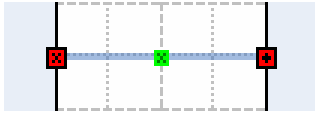

- If either of the two shapes were to move, the connector would stay fixed to the same two connection points:

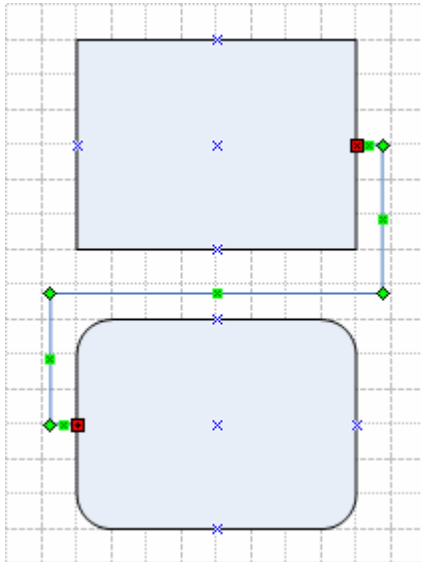

CREATING A SHAPE-TO-SHAPE CONNECTION

- Choose the Connector Tool .
- Move the mouse over the first shape. The whole shape becomes selected:

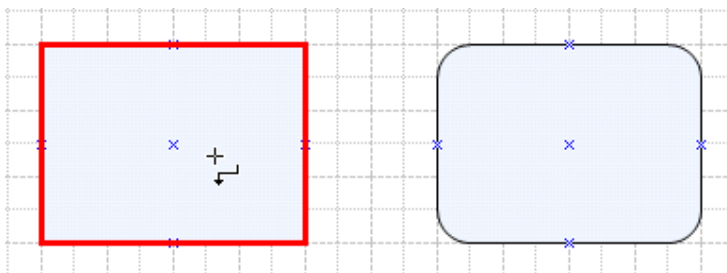

- Click & Drag over to the second shape. It will also become selected:

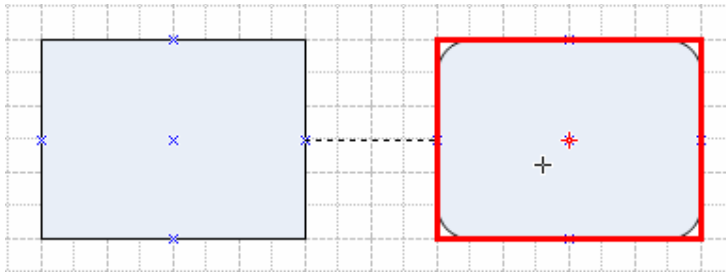

- The connector is now fixed to the two shapes. This is indicated by the larger, empty red squares:

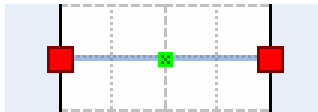

- If either of the two shapes were to move, the connector would move to the two closest connection points:

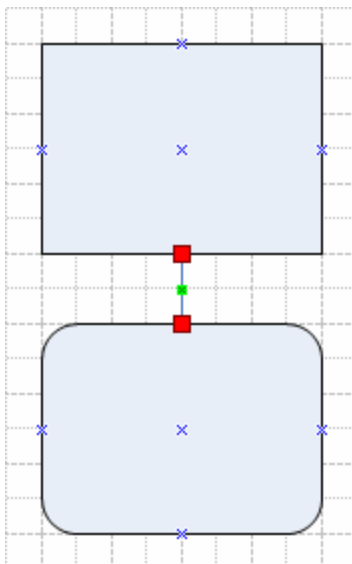

CONNECTING MULTIPLE SHAPES

- Select the shapes you want to connect.
- Choose the **Connect Shapes** from the **Shape** menu.
- This forms a Shape-to-Shape Connection between the shapes.

AUTOMATICALLY CONNECTED SHAPES

- Choose the Connector Tool .
- Select the shape you require and drag onto the page.
- Select another shape you require and drag onto the page.
- Shapes are automatically connected using a Shape-to-Shape connection.

WORKING WITH CONNECTION POINTS

Sometimes you may want to have connection points in specific positions on a shape. Visio has predefined connection points, but these can be altered.

ADDING A CONNECTION POINT

- Select the shape.
- Choose the **Connection Point Tool** from the Connector Tool drop-down:

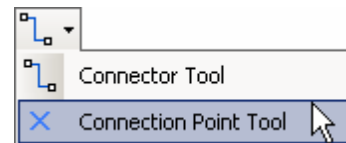

- Move your mouse pointer to the position on the shape where you want to add a connection point.
- Hold down the **CTRL** key, the mouse pointer will be carrying a small cross at the tip.
- Click the mouse and the extra connection point will be added.

DELETING A CONNECTION POINT

- Choose the **Connection Point Tool**.
- Click on the connection point you want to delete.
- The connection point will go pink.
- Press the **Delete** key.

Drawing Shapes

As well as offering a multitude of shapes in its stencils, Visio also provides tools to enable the drawing of shapes. The Drawing toolbar is activated using the Drawing Tools icon on the standard toolbar:

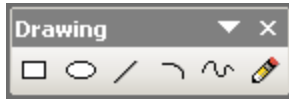

- Click onto the appropriate tool for the shape you want to draw.
- Move the mouse cursor onto the drawing page.
- Click and drag to produce the shape or line.

The tools are divided into shape tools and line tools.

Shape



Rectangle Tool

For a rectangle or a square. Click and drag a frame for the shape, from one corner diagonally across to the opposite corner.

For a square, hold down the **SHIFT** key as you are dragging.



Ellipse Tool

For an ellipse or a circle. Click and drag a frame for the shape, from one corner diagonally across to the opposite corner.

For a circle, hold down the **SHIFT** key as you are dragging.

Line



Line Tool

For straight lines. Click and drag from the start point to the finish.

Holding down the **SHIFT** key will ensure the lines are at 45° increments.



Arc Tool

For arcs. Click and drag from the start point to the finish.

Choose the pointer tool to adjust the curve with the control handle.



Freeform Tool

For an irregular shape.

'Bend' points are provided for adjusting the shape.

**Pencil Tool**

The pencil tool can be used to draw both straight lines and arcs. It uses 'gesture-recognition' to decide which type of line to create.

Background Pages

Each Visio drawing contains at least one page; its foreground page. A drawing may also contain one or more background pages. When you assign a background page to a foreground page, the shapes on the background page are also visible on the foreground page. This can be a very useful way of displaying a logo, for example.

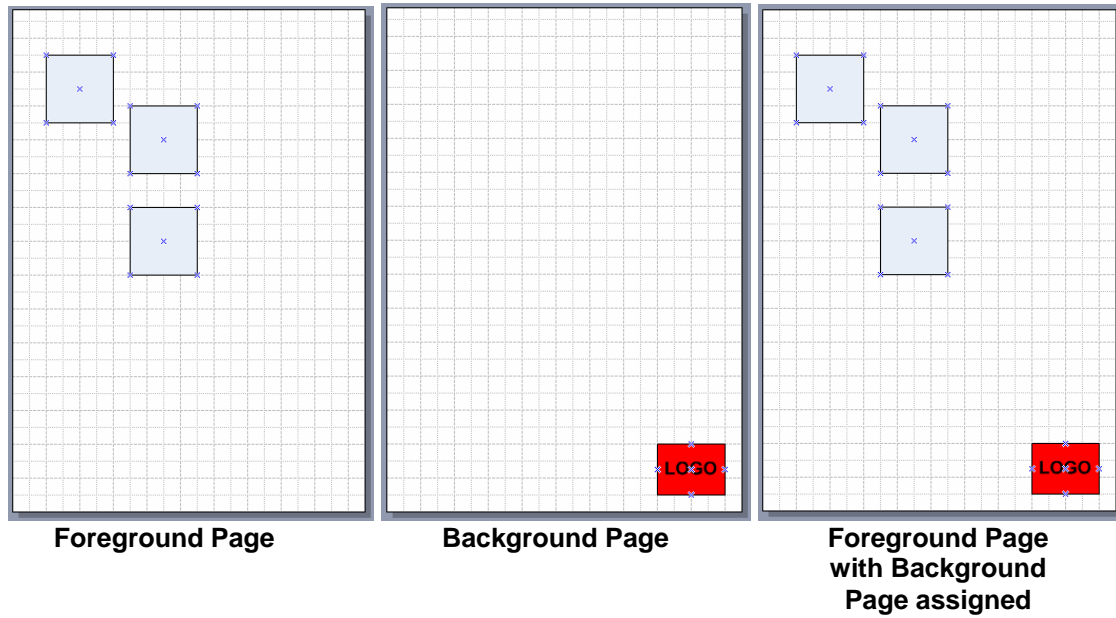

You can assign only one background page to a foreground page, but each background page can also have its own background page. This allows multiple background pages to be used to create a layered effect.

INSERTING A BACKGROUND PAGE

- Choose **New Page** from the **Insert** menu.

- In the **Page Setup** box, choose **Background** from the **Type** section:

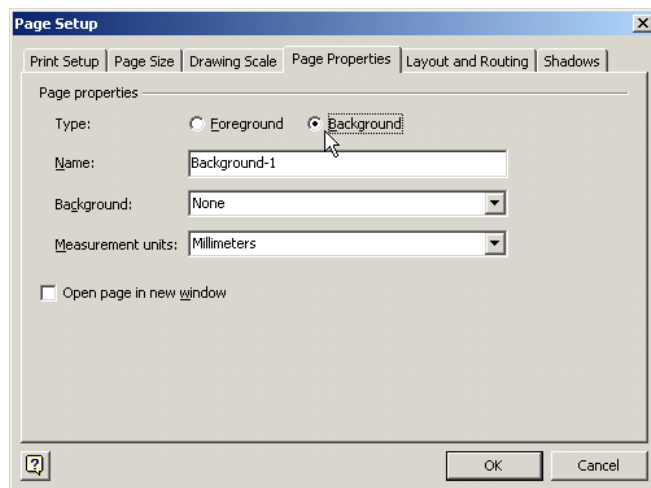

- Visio will give a default name of 'Background-1', until you create a new name.
- Choose **OK**.
- Design the layout of the background page.

ASSIGNING A BACKGROUND PAGE

- Display the foreground page for which you wish to assign a background page.
- Choose **Page Setup** from the **File** menu. Click onto the **Page Properties** tab.
- Choose the desired Background page from the drop-down:

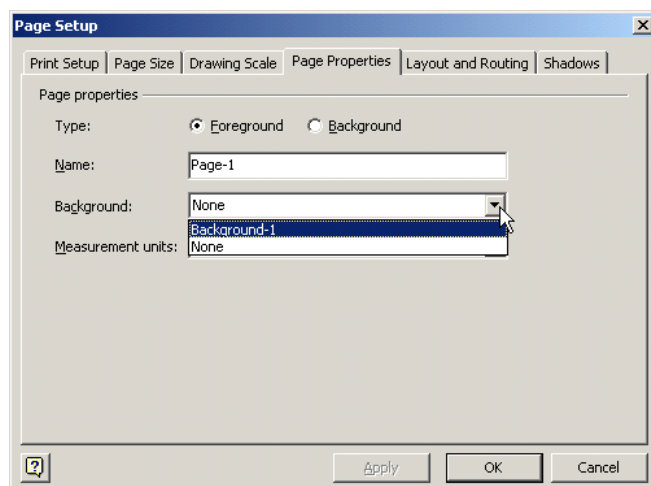

- Choose **OK**.

CREATING A BACKGROUND PAGE FROM AN EXISTING PAGE

- Display the foreground page you wish to become the Background Page.
- Choose **Page Setup** from the **File** menu. Click onto the **Page Properties** tab.
- Select **Background** from the **Type** section.
- Choose **OK**.

EDITING AN EXISTING BACKGROUND PAGE

- Display the background page as you would a normal foreground page:

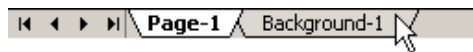

- Edit as normal.

Custom Stencils

The Favourites stencil is one that is automatically created when you install Visio and is located in the My Shapes folder, in My Documents. It can be used to store shapes that you use often, those that you create yourself, or even your customised versions of shapes from other stencils.

THE FAVOURITES STENCIL

ADDING SHAPES FROM AN EXISTING STENCIL TO FAVOURITES

- Locate the shape (on any stencil).
- Right-click on the required shape.
- Select **Add To My Shapes** then **Favourites**:

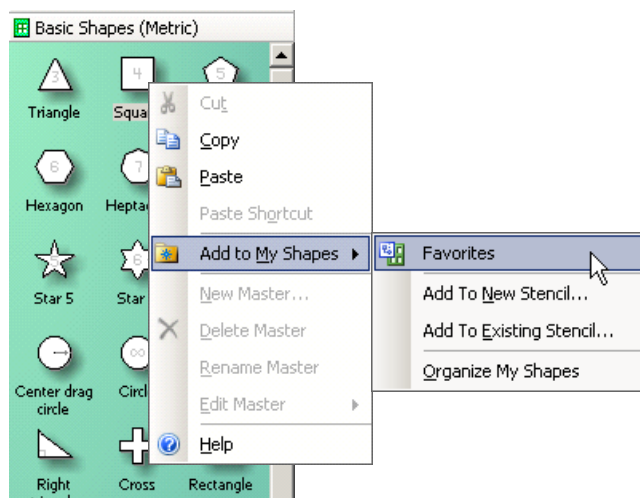

VIEWING FAVOURITES

- From the **File** menu, choose **Shapes** then **My Shapes** and **Favourites**:

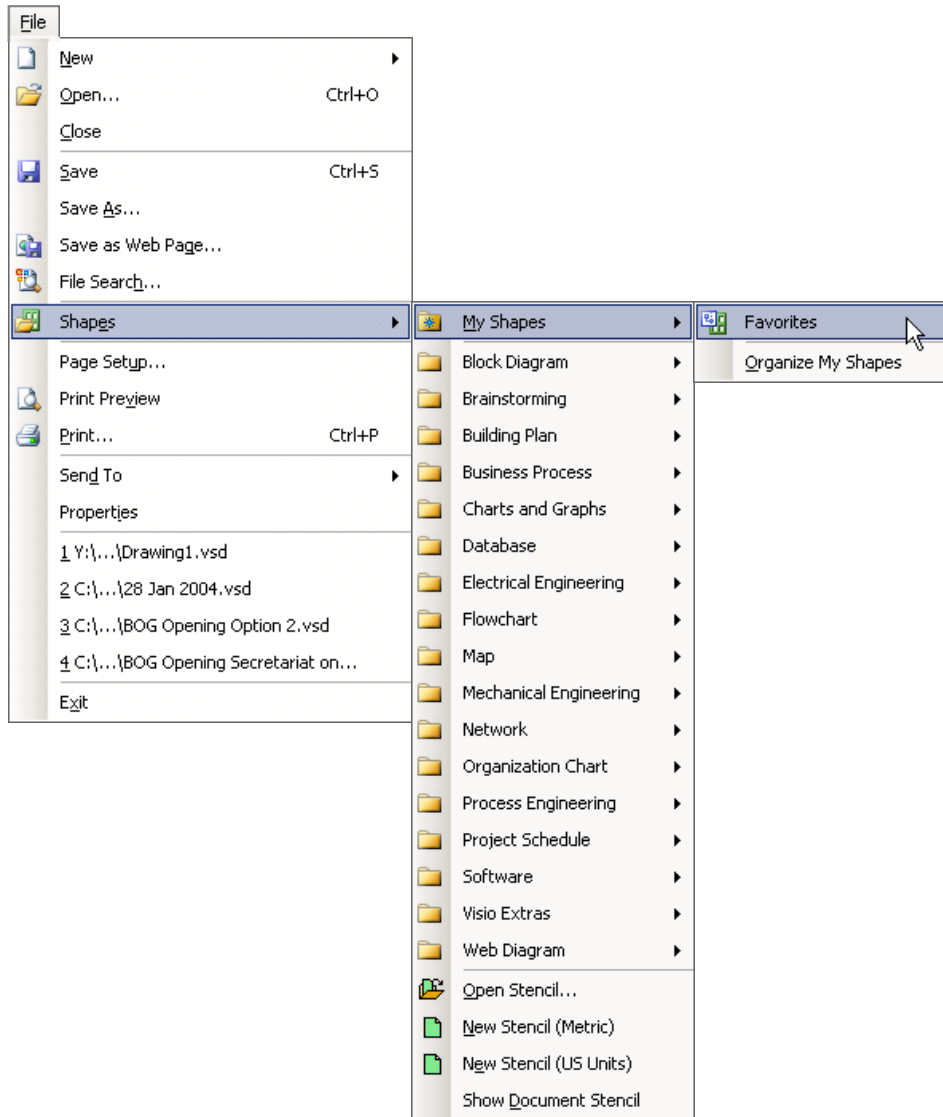

- Favourites will open below your current stencils:

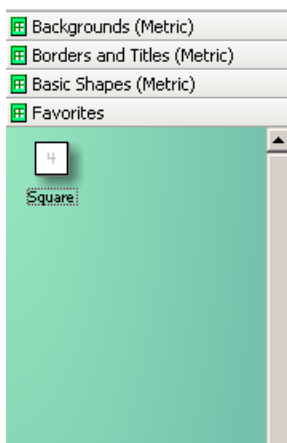

- Shapes on this stencil can be used in exactly the same way as those from any other.

ADDING SHAPES FROM A DRAWING TO FAVOURITES

- View the Favourites as described in the previous point.
- Right-click on the title 'Favourites' and choose **Edit Stencil**.

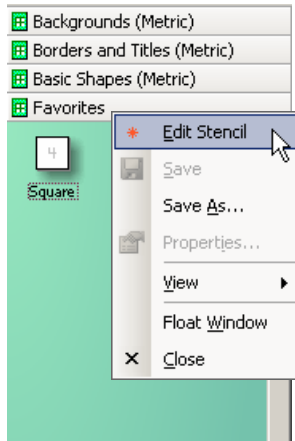

- A red star will now appear on the icon:



- From the drawing page, simply drag your shape onto the Favourites stencil.
- It will appear with a name such as 'Master.4'.
- Right-click the new 'master' and choose **Rename** if you want to change the name.

SAVING CHANGES TO FAVOURITES

- Any time a new shape is added to the Favourites stencil, a disk icon will appear in the corner of the stencil as a reminder to save the changes:



- Click onto this disk icon to save the changes. It will disappear once it has been clicked onto.

NEW STENCILS

Although the Favourites makes it easy to store and access shapes, other stencils can also be created.

CREATING A NEW STENCIL

- From the **File** menu, choose **Shapes**, then **New Stencil**.
- The **Blank Stencil** will appear:

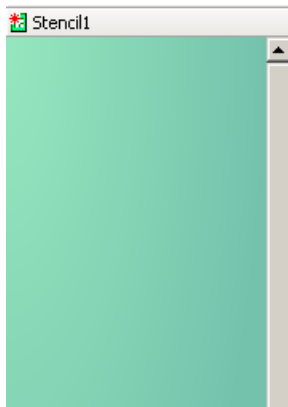

ADDING SHAPES TO THE NEW STENCIL

- This can be done by dragging shapes onto the stencil, either from an existing stencil or from the drawing page.

Printing

PRINT PREVIEW

It can be quite useful to see your drawing before you print it.

- Choose **Print Preview** from the **File** menu.

OR

- Choose the Print Preview icon  from the Standard Toolbar.
- When you have finished previewing your drawing, choose **Close** from the **Print Preview** toolbar:

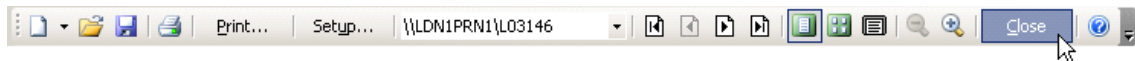

PRINTING YOUR DRAWING

- From the **File** menu, select **Print**:

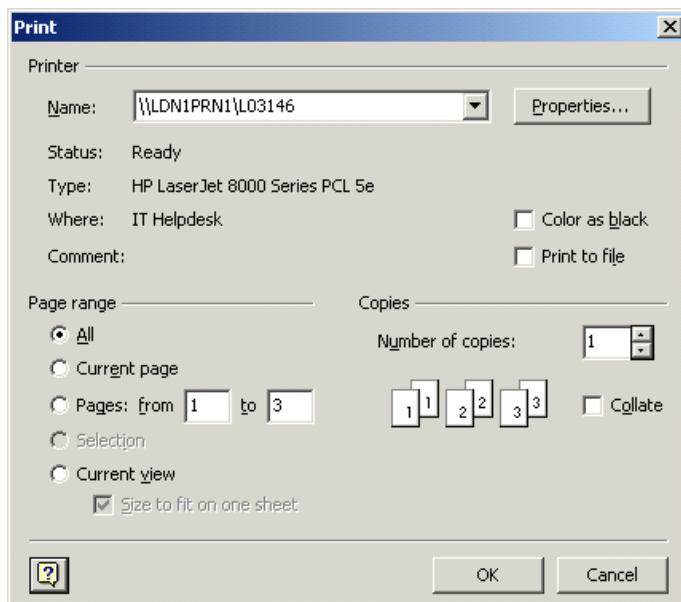

- The Page Range section gives the following choices:

All	Prints every page in the drawing file in the order in which they appear.
Current Page	Prints the currently displayed drawing page.
Pages:	Prints only the specific range of pages identified by the values you type in the From and To boxes.
Selection	Prints the currently selected shapes.
Current View	Prints the part of the drawing that shows in the program window.

- Make your choice and choose **OK**.

Visio & Other Applications

Visio drawings can be easily copied into other applications such as Word or PowerPoint.

- Select the shape (or shapes) on your Visio drawing. Remember **CTRL+A** is a quick way to select all shapes on a page.
- Copy these (using the Edit menu or toolbar icon).
- Go to your Word document (for example), and Paste.
- The shapes are automatically pasted as a grouped object to make it easier to move or resize them.

Keyboard Shortcuts

CTRL+A	Select all the shapes on the active drawing page.
CTRL+C	Copy the selection to the Clipboard.
CTRL+D	Duplicate the selection.
CTRL+G	Group the selected shapes.
CTRL+H	Flip the selected shape horizontally.
CTRL+J	Flip the selected shape vertically.
CTRL+L	Rotate the selected shape to the left.
CTRL+N	Open a new drawing based on the open drawing.
CTRL+O	Open an existing drawing.
CTRL+P	Open the Print dialog box.
CTRL+R	Rotate the selected shape to the right.
CTRL+S	Save the drawing.
CTRL+V	Paste the contents of the Clipboard.
CTRL+W	Zoom to show the whole page.
CTRL+X	Cut the selection to the Clipboard.
CTRL+Y	Reverse the action of the Undo command.
CTRL+Z	Undo the last action you performed.
<hr/>	
CTRL+SHIFT+B	Send the selected shape to the back.
CTRL+SHIFT+F	Bring the selected shape to the front.
CTRL+SHIFT+U	Ungroup the selected group.
<hr/>	
CTRL+ENTER	Insert the selected master shape into the drawing (from stencil).
CTRL+F4	Close the active drawing window.
CTRL+ drag shape	Copy the selected shape.

SHIFT+ drag shape Move the selected shape in a straight line (up/down or left/right).

CTRL+SHIFT+
left mouse click Zoom in at mouse pointer position.

CTRL+SHIFT+
right mouse click Zoom out from mouse pointer position.

ALT+F6 Zoom in.

ALT+SHIFT+F6 Zoom out.

F4 Repeat the previous action.

F8 Open the Align Shapes dialog box.

F12 Open the Save As dialog box.